



# TEACHER GUIDE

TEXAS

 **Xcel**Energy®



# Table of Contents

## Welcome

STEM Connections . . . . . 1

## Natural Resources

The Search for Energy . . . . . 2

Let's Play LINGO! . . . . . 5

## Energy Transformations

Energy for Electricity. . . . . 10

## Electricity and Circuits

The Art of Circuits . . . . . 13

Shine a Light on History . . . . . 15

## Natural Gas

Layered Lunch . . . . . 19

Natural Gas Mix and Match. . . . . 21

## Water

Water Inside and Out . . . . . 25

## Energy Efficiency

The Cost of Looking Your Best. . . . . 29

# Welcome

The Xcel Energy School Education program is available to schools through your local utility. You and your students are energy champions through your participation. The goal of the program is to help families learn about energy. Using energy wisely saves energy and money while helping to conserve natural resources.

This *Teacher Guide* contains supplementary energy education. At your own discretion, use the activities you choose to meet the needs of your students.

The lessons in this guide are multidisciplinary and are correlated to Texas Essential Knowledge and Skills for Science and STEM. Each lesson contains an objective, curriculum focus, materials needed, key vocabulary and detailed state learning standard correlations, in addition to the full procedures for teaching the lesson. Some lessons contain student sheets; others are to be done as class discussions or demonstrations.

STEM Connections	Science				Technology				Engineering				Math				
	Science as Inquiry	Energy Sources, Forms and Transformations	Science and Technology	Personal and Social Perspectives	Productivity Tools	Communication Tools	Research Tools	Problem-solving and Decision-making Tools	Historical Perspective	Design and Modeling	Invention and Innovation	Test Design and Troubleshooting	Use and Maintain	Numbers and Operations	Measurement	Data Analysis and Probability	Connection to the Real World
<b>Activity</b>																	
The Search for Energy	•	•	•	•										•		•	•
Let's Play LINGO		•		•		•											•
Energy for Electricity	•	•	•	•						•							
The Art of Circuits	•	•	•					•		•	•	•					•
Shine a Light on History		•	•	•		•	•	•	•		•						•
Layered Lunch	•		•							•							•
Natural Gas Mix and Match		•		•													•
Water Inside and Out		•	•	•	•	•	•	•						•	•	•	•
The Cost of Looking Your Best	•	•	•	•	•	•	•	•						•	•	•	•

# The Search for Energy

## Objective

Students will learn the difference between renewable and nonrenewable resources.

## Curriculum Focus

Math  
Science  
Social Studies

## Materials

- 1/2 bag popcorn or other small item to represent solar energy
- Small pieces of ripped paper to represent approximate U.S. nonrenewable energy reserves
  - 164 black: coal
  - 22 red: uranium
  - 8 green: natural gas
  - 2 blue: oil
- Large sheet or tarp to place paper and popcorn on for easy clean up (optional)
- Copies of "Student Sheet: Data Table and Graph"

## Key Vocabulary

Nonrenewable resources  
Renewable resources

## Texas Essential Knowledge and Skills for Science

Grade 5  
(b) 1.B  
(b) 5.C  
(b) 10.A, B  
(b) 11  
(b) 12.C  
  
Grade 6  
(b) 1.B  
(b) 5.C  
(b) 11.A, B



## Introduction

Fossil fuels are extremely useful energy sources. Our society has adopted them because they can be readily available and economical. In the early part of the 20th century, a fledgling solar industry took root but was ultimately displaced by less expensive energy sources such as fossil fuels. Today some fossil fuels are harder to find and increasingly more costly. The sun, on the other hand, is just as plentiful as it was 100 years ago. It is a renewable resource that could become our most widely used source of energy. Please note that data for U.S. nonrenewable energy reserves is approximate and should not be considered absolute to the date of the activity.

The following activity is a simulation game in which students learn the difference between renewable and nonrenewable resources. The game reflects society's use and exhaustion of nonrenewable fuels and the eventual transition to renewable technologies.



## Procedure

1. Divide the class into five equal groups. Each group will be a company going after a particular resource (coal, uranium, natural gas, oil or the sun). The paper and popcorn represent reserves of the various energy resources. Pass out copies of "Student Sheet: Data Table and Graph" to each group or have students create their own data tables on paper.
2. Have students gather in a large circle. Scatter the papers plus a handful of "solar" popcorn so they are well spread out in the center of the circle. You can do this on a sheet for easier clean up. Explain that this exercise demonstrates how the availability of resources changes over time. You may want to designate certain places as protected areas, where the resources are off limits to protect the environment.

To learn more, visit [thinkenergy.org/XcelEnergy](http://thinkenergy.org/XcelEnergy).

3. Tell students you will do several trials and look to see how the types of resources that are available change after each trial. Tell each group that they will have 30 seconds to pick up as many papers or popcorn as they can of their assigned type. Start timing.  
  
After 30 seconds have the groups stop and count the items they have gathered. Have each group announce their results to the class and record every count in their data table. If some groups have collected all of their available resource, point out that the resource is now depleted and they are unemployed.
4. Scatter another handful of "solar energy," helping students realize that since the sun is a renewable resource, there is the same amount of it each time you look, whereas the nonrenewable fuels are being depleted. Repeat the search period so students can get more papers or popcorn.
5. Stop after 30 seconds and have the group count and record the papers and popcorn collected again. Note that there are fewer nonrenewable fuels found in the second round. Students have to look harder to find what is left. The solar count is slowly catching up with the nonrenewable fuels. Repeat with additional trials as needed.
6. Have groups create a bar chart or, for more advanced students, a multiline graph of the number of papers and popcorn collected each trial.



---

## Discussion

- Why does the solar line differ from the others? Why does it go up rather than down?
- How do improvements in technology affect the extraction of resources from the earth?
- How do improvements in technology affect our usage of renewable resources?
- In the real world, can we extract ALL of a resource? Why do some deposits go unused?



---

## To Know and Do More

Add wind and water to the activity. Lead a discussion to be sure the students understand why you continued adding more sun, wind and/or water after each trial, but did not add more of the other papers. As a class, come up with a general outline of how to more effectively manage the resources that are available to us.

## Student Sheet: Data Table and Graph

**Data Table**

Search Period	Coal (Black)	Uranium (Red)	Natural Gas (Green)	Oil (Blue)	Sun/Solar (Popcorn)
1					
2					
3					
4					
Totals					

**Data Graph**

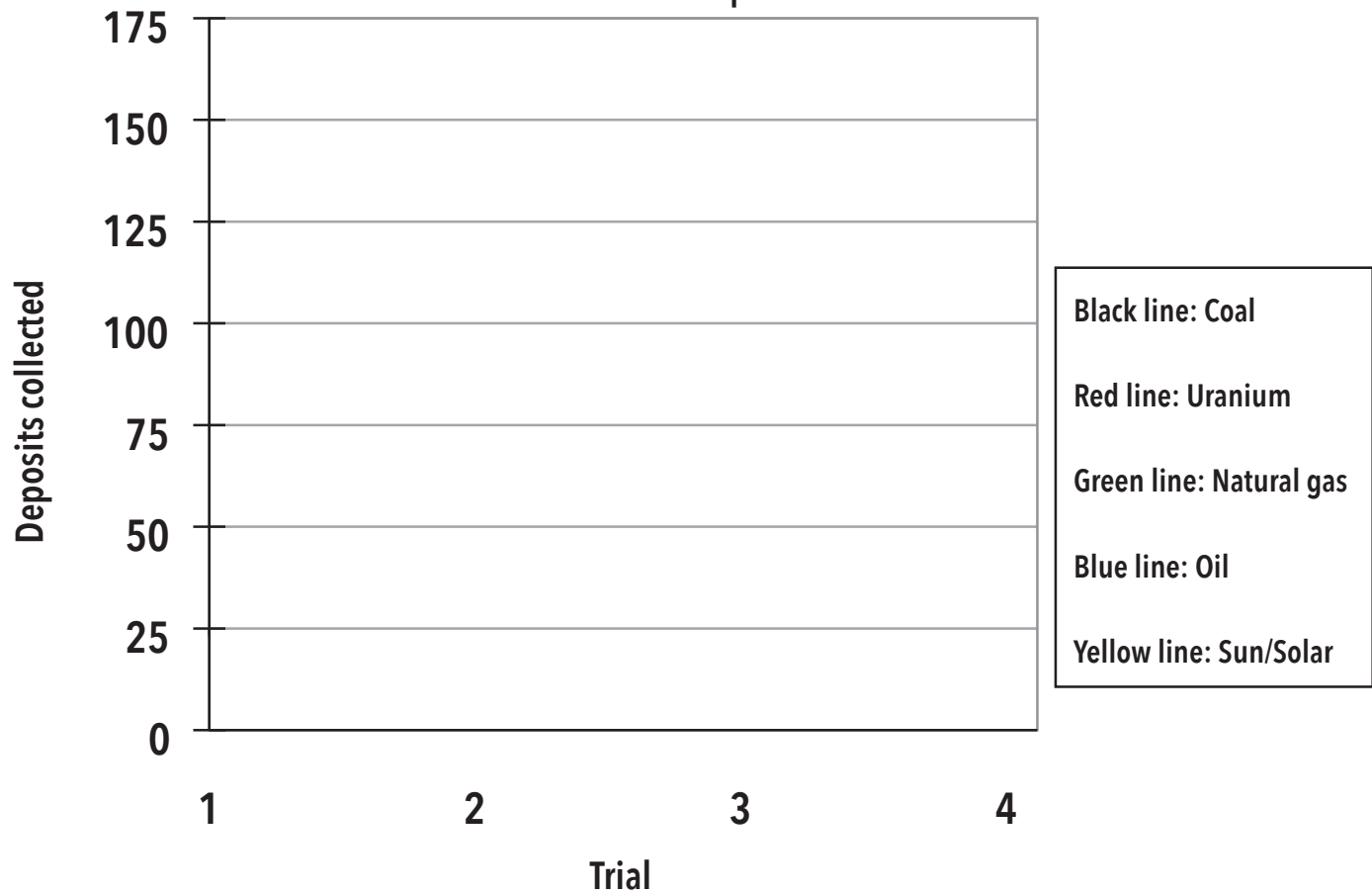

To learn more, visit [thinkenergy.org/XcelEnergy](http://thinkenergy.org/XcelEnergy).

## Let's Play LINGO!

### Objective

Students will become familiar with various energy sources as a result of playing a word game.

### Curriculum Focus

Language Arts  
Science

### Materials

- Word definition strips, cut apart
- LINGO card for each student
- Objects to use as markers

### Key Vocabulary

Btu, charcoal, chemical energy, coal, crude oil, electricity, energy, fission, food, fossil fuels, fuel, fusion, gasoline, geothermal, hydrocarbon, hydroelectric, natural gas, nuclear energy, oil shale, petroleum, primary energy, refuse, renewable energy, resources, secondary energy, solar energy, thermal energy, tidal power, uranium, wind, wood

### Texas Essential Knowledge and Skills for Science

Grade 5  
(b) 5.C, D  
(b) 10.A, B  
(b) 11  
(b) 12.C

Grade 6  
(b) 5.C, D  
(b) 11.A, B



### Introduction

The same energy sources that are available today were available thousands, even millions of years ago but we use a lot more energy today than was used in the past. Resource deposits have been discovered and new uses have been found for them. Years ago petroleum was used to waterproof boats and canoes; later it was used for heat and light but a by-product, gasoline, was discarded. Then came the "horseless carriage" and suddenly the gasoline refined from petroleum became an important commodity. Today we get thousands of products from petroleum. Resources are being used worldwide at a rate never before known. Experts and environmentalists are concerned that our supplies may be depleted. Because of this, it is important to use our resources wisely and efficiently.

There are two main categories of energy sources, renewable and nonrenewable. Renewable sources of energy cannot be depleted. We can chop down a tree but five more can be planted. We can use the sun's energy today and there will still be more tomorrow. Nonrenewable resources are sources of energy that can be depleted. There are limited amounts of oil and coal that can be taken from the earth. Once they are gone we cannot get more. We need to be careful how we use our nonrenewable sources of energy so they will be available for many generations.



### Procedure

1. Introduce the activity by indicating that the class is going to play a word game.  
a free space. Students may mix the words any way they wish. Explain that LINGO is played like BINGO.
2. Distribute the LINGO cards and instruct students to write one of the vocabulary words from the word bank at the bottom of the board in each of the squares, leaving the middle space as
3. Distribute space markers.



4. Have the caller draw definition strips from a bag or box. Read the definition only. If the students can match the definition with a word on their list, then they should place a marker over that word. Continue until a student has a LINGO, a complete line vertical, horizontal or diagonal.
5. The student who calls "LINGO" must then read all the words in their LINGO to verify that the definitions were correctly identified and match the words called.
6. After several plays, go over each word and definition with students. You may wish to repeat the game in one week to check retention.



## Discussion

Learning to use the dictionary is important. Have students define the energy words used in this activity. For fun have a dictionary scramble. Call out a word from the word bank and see who can be the first to find it in their dictionary.

Renewable	Nonrenewable
geothermal	oil, petroleum
ocean tides, waves	nuclear energy, uranium
hydroelectric	coal
biomass, plants, wood	natural gas
solar	methane
garbage	gasoline
wind	battery



## To Know and Do More

Have students categorize the LINGO vocabulary words. Brainstorm to get the categories (for example, renewable, nonrenewable, fossil fuels, products, energy sources, gases, solids, etc.).



## Career Awareness Activity

Help students identify various careers that would deal with renewable and nonrenewable resources. For example, a seismologist may work for a petroleum exploration company. A hydrologist could work for a mining, geothermal or for a hydroelectric company.

Choose some energy related careers and use them as tiebreakers or bonus rounds in your energy source word game.

# L I N G O

		FREE		

## Word Bank

Btu, charcoal, chemical energy, coal, crude oil, electricity, energy, fission, food, fossil fuels, fuel, fusion, gasoline, geothermal, hydrocarbon, hydroelectric, natural gas, nuclear energy, oil shale, petroleum, primary energy, refuse, renewable energy, resources, secondary energy, solar energy, thermal energy, tidal power, uranium, wind, wood

## WORD DEFINITION STRIPS

A combustible gas found in the earth used to heat homes, water and cook food

(natural gas)

Formed from marine animal and plant material at the bottom of ancient seas, usually a black liquid

(crude oil)

Energy produced from other energy sources, for example electricity

(secondary energy)

A secondary energy source; a form of kinetic energy obtained when electric charges are set in motion by an electromotive force

(electricity)

The ability to do work or cause change

(energy)

A measure of heat energy (British thermal unit)

(Btu)

A molecule made of hydrogen and carbon atoms; makes up coal, oil and natural gas

(hydrocarbon)

A black combustible solid formed from plants, often used to generate electricity

(coal)

Energy produced by changes in the nucleus of atoms

(nuclear energy)

Radiation energy from the sun, the primary source of all energy

(solar energy)

A fuel produced from refined crude oil

(gasoline)

The fuel used in a nuclear reactor to generate electricity

(uranium)

A form of energy contained in coal, natural gas and oil, also stored in batteries

(chemical energy)

A form of energy produced from the combustion (burning) of coal, oil, natural gas or the fission of uranium

(thermal energy)

A solid fuel formed from the conversion of the sun's energy through photosynthesis

(wood)

Electrical energy produced by a water-powered turbogenerator located inside a dam (hydroelectricity)	Useless, unwanted or discarded materials (garbage); can be used to generate electricity or produce natural gas (refuse)
A form of kinetic (moving) energy produced in part by the sun's heating of the earth (wind)	A naturally occurring material (gaseous, liquid or solid) composed mainly of chemical compounds of carbon and hydrogen (petroleum)
A source of energy using heat from within the earth (geothermal)	Power obtained from falling and rising ocean tides (tidal power)
Formed from ancient plants and plankton, such as coal, oil, natural gas (fossil fuels)	Energy in its naturally occurring form, such as coal, oil, natural gas (primary energy)
A substance which is used to produce thermal energy (fuel)	The splitting of atoms to release energy (fission)
Stored chemical energy produced by the conversion of solar energy through photosynthesis and a source of energy for animals (food)	A sedimentary rock that yields crude oil when heated (oil shale)
A source of energy that can be naturally replaced such as the sun or wind (renewable energy)	A carbon containing material produced by the heating of wood and often used as a fuel for cooking (charcoal)
The combining of atoms to release energy (fusion)	

## Energy for Electricity

### Objective

Students will describe energy transformations required to produce electrical energy for homes.

### Curriculum Focus

Science  
Technology

### Materials

- Copies of "Student Sheet: Electrical Generation Puzzle," cut apart
- Pinwheel (optional)
- Hand generator (optional)
- Transformer from a household item such as a cellular phone charger (optional)

### Key Vocabulary

Boiler  
Generator  
Transformer  
Turbine

### Texas Essential Knowledge and Skills for Science

Grade 5  
(b) 1.B  
(b) 5.C  
(b) 7.A  
(b) 11

Grade 6  
(b) 1.B  
(b) 5.C  
(b) 7.A  
(b) 11.A, B



## Introduction

Electrical generation requires many energy transformations. In this activity, students will complete a puzzle showing the steps in the generation process and see how electricity is delivered to homes. Though it is a simple puzzle, students generally have no idea how electricity is produced until they have completed this activity.



## Procedure

1. Ask students if they believe that energy is important to their lives. How would their lives be different without electricity?
2. Ask students where electricity comes from and how it is made. Tell them that the process of generating and delivering electricity requires many energy transformations.
3. Pass out the "Electrical Generation Puzzle" pieces and give students a few minutes to put the pieces in order. (boiler, turbine, generator, power line, transformer, consumer)
4. Go through each step of the puzzle, asking students to give the type and form of energy going in and coming out of each step. Point out that burning the fuel in the boiler is a chemical change that breaks the bonds of the hydrocarbons in the fuel to release thermal energy (and waste products such as carbon dioxide and sulfur dioxide). Compare the turbine to the pinwheel, demonstrating how steam can turn the turbine to create mechanical energy. Use the hand generator to show how the mechanical energy of the turbine is converted to electrical energy. If you have done "Get Your Motor Running," you can compare a generator to a motor.

5. Explain that the purpose of the transformers is to increase or decrease the voltage. Step-up transformers are needed to replace voltage lost as electricity is converted to thermal energy by electrical resistance in the power lines. Many household electronic devices have step-down transformers, which are a miniature version of those on electrical poles. These small transformers commonly also contain components to convert the alternating current (AC) from an outlet into direct current (DC).
6. Have students name some further energy transformations that occur once electricity is used in their homes.
7. Ask students how the process of generating electricity with alternative energy sources would vary from the fossil fuel power plant shown in the puzzle. Which pieces would be different or removed when using each one of the following: nuclear power, wind power, hydropower and solar power?
8. Have students discuss the environmental effects of using fossil fuels versus alternative fuels.
9. List advantages and disadvantages of each method of producing electricity. Each energy source has benefits and drawbacks that must be considered and balanced.

## Description of Electrical Generation Process

1. Boiler: These convert chemical potential energy from fuel (fossil fuels, biomass, hydrogen) to thermal kinetic energy, changing water to steam. Light and chemical energy (new chemicals in the gases produced) are also formed but the energy does not contribute to the process of electrical generation.
2. Turbine: Turned by steam, turbines convert thermal kinetic energy to mechanical kinetic energy. Thermal energy from friction within the mechanism is produced as well but does not contribute to the electrical generation process.
3. Generator: Turned by the turbine, it rotates a coil of wire in a magnetic field converting mechanical kinetic energy to electrical kinetic energy. Thermal energy from friction within the mechanism is produced as well but does not contribute to the electrical generation process.
4. Power lines: These transmit electrical energy at several thousand Volts. Resistance heating in wires converts electrical energy back to thermal energy, resulting in a voltage drop and a loss of usable energy. High voltage lines from a power plant are called transmission lines. The transmission lines run to a substation which contains transformers and switches.
5. Transformer: Substations and transformers may be step-up or step-down. Step-up transformers along the power lines increase voltage periodically; step-down transformers, on poles or in yards, reduce the voltage to a safe level for home use.
6. Consumer: Consumers convert electrical energy into many forms to run lighting and home appliances.



## To Know and Do More

Investigate how transformers work. The website below is a useful guide to show how transformers step voltage up and down and how household transformers also convert AC to DC.

Check out [explainthatstuff.com/transformers.html](http://explainthatstuff.com/transformers.html) and [science.howstuffworks.com](http://science.howstuffworks.com) for detailed information on how power grids work.

If you have access to a voltmeter, have students design and build transformers. Test the voltage in and out of transformers and compare to the number of turns of wire on each core. Have students see if they discover a pattern.

## Student Sheet: Electrical Generation Puzzle

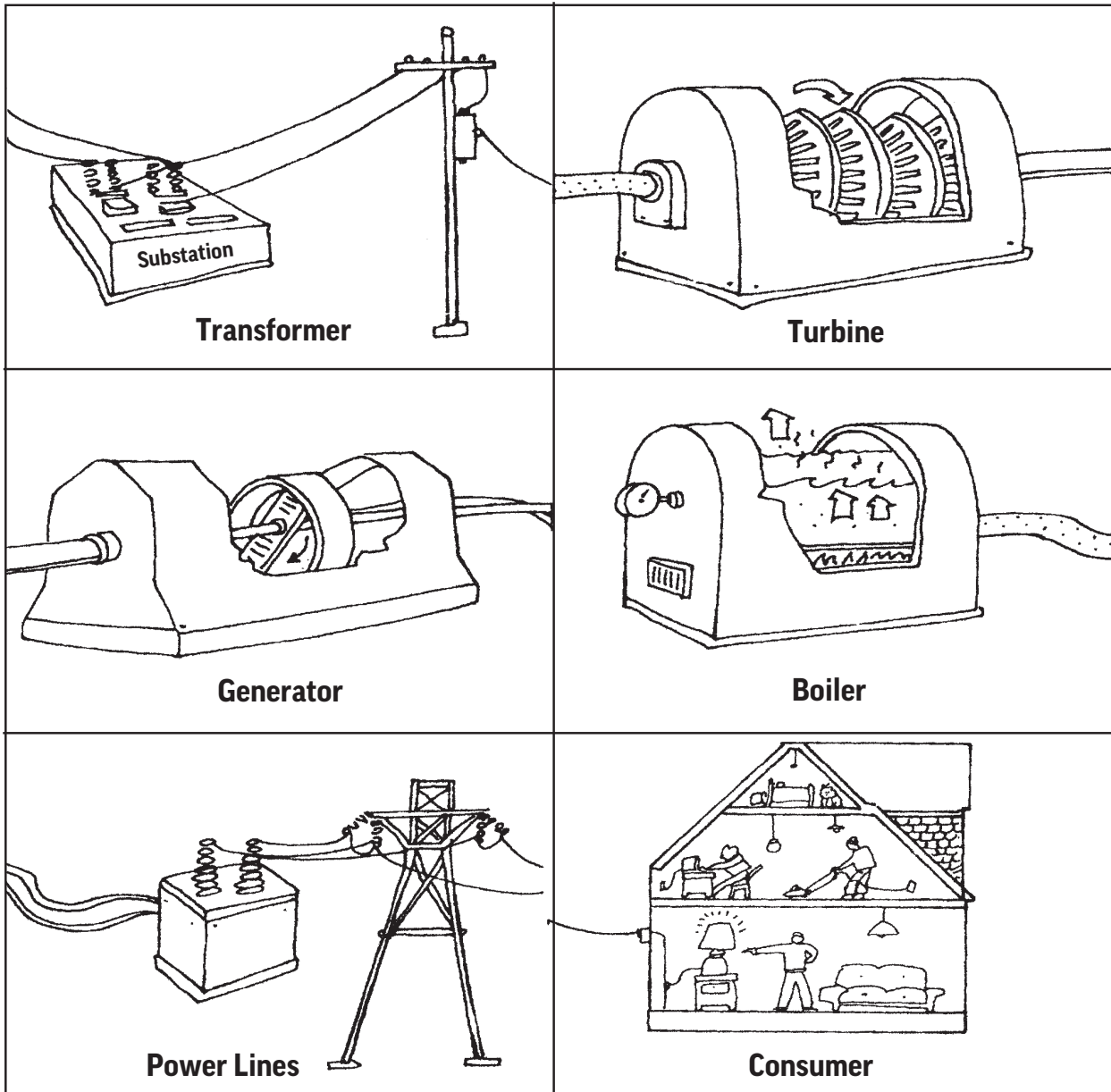

## The Art of Circuits

### Objective

Students will learn about conservation of energy and energy transfer by experimenting with electrical circuits.

### Curriculum Focus

Science  
Social Studies  
Language Arts  
Art

### Materials

- Playdough® or homemade salt dough
- 9V batteries
- 9V battery clips with red and black cables
- 2V LED miniature light bulbs
- Insulating material: cardboard, packaging plastic or dough made from sugar, not salt (optional)

### Key Vocabulary

Energy transfer  
Electric current  
LED (light-emitting diode)  
Electric circuit  
Insulator  
Conductor

### Texas Essential Knowledge and Skills for Science

Grade 5  
(b) 1.B  
(b) 2.A, B, C, D  
(b) 5.C  
(b) 8.A, B

Grade 6  
(b) 1.B  
(b) 2.A, B, C, D  
(b) 5.C  
(b) 8.B



### Introduction

Materials that allow a flow of electric current to pass through them more easily are called conductors. Aluminum, silver and copper are examples. Insulators block the flow of electricity. Nonmetallic materials, such as rubber, plastic, wood, cloth and dry air, are insulators. An electrical circuit is a path of conductors through which electric current flows. Energy can be transferred from place to place by electric current.

In this activity students will use salt dough, which is a conductor, to design circuits which will transfer electrical energy. If they are successful the electricity will be transformed to light and heat energy in a miniature LED bulb.



### Procedure

1. Introduce students to their materials:
  - a. Attach the battery to a battery clip with red and black cables. The red lead is the positive terminal and the black lead is the negative terminal.
  - b. Examine the LED bulb. Two wires (or legs) extend from the bulb. The longer wire is the positive side of the LED and the short wire is the negative side. The LED should only be connected to dough, never directly to the battery terminals, which will cause the bulb to burn out.
2. Tell students that electricity can only go through the circuits they will create in one way. The positive terminal of the battery (red lead on battery clip) must be nearest a positive (long) leg of the LED. A battery pushes electricity around the circuit through the positive leg and out the negative (short) leg, then repeating through the next positive leg (if there is more than one LED in the circuit).
3. Explain that electricity will take the path of least resistance. It is easier for electricity to travel through the dough than through the LED, so if two pieces of dough are touching, the LED will not light.
4. Challenge students to design a simple circuit like the ones on the next page.



### SERIES CIRCUIT

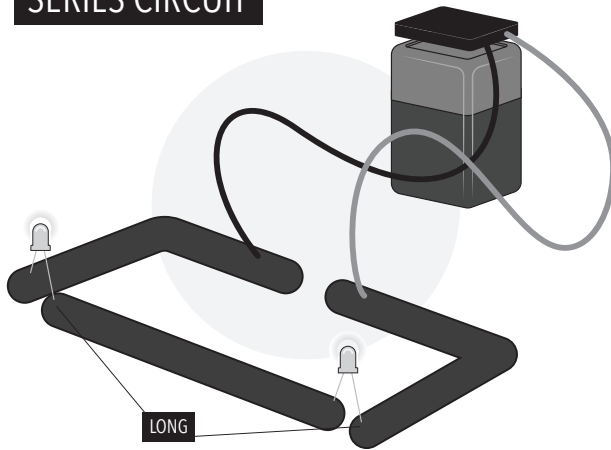

### PARALLEL CIRCUIT

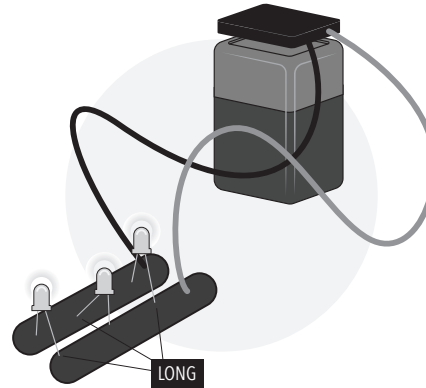

If time allows, have students create a circuit work of art like the one below. Since the conductive dough cannot touch, use insulating material between layers.

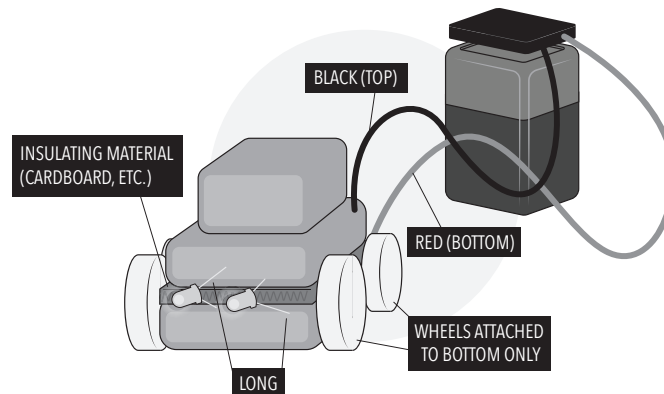

### Discussion

- How does your dough circuit light the LED compared to the circuits at your home?
- In a series circuit with multiple LEDs, what happens to the brightness of the LEDs that are further from the battery? Why?



### To Know and Do More

When a light switch is off, the electrical pathway to a bulb is not complete and electricity cannot flow to light that bulb. When you flip the switch on, you close the circuit and the light turns on. If light is not needed, it is important not to waste the natural resources used to generate the electrical power that is being transformed to light. Have students create characters without noses to put over light switches at school or home. The art should help remind them to turn lights off!

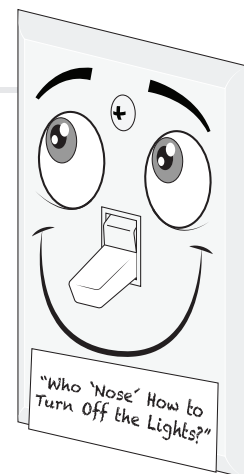

To learn more, visit [thinkenergy.org/XcelEnergy](https://thinkenergy.org/XcelEnergy).

## Shine a Light on History

### Objective

Students will gather details and make inferences from text to explain historical events related to electricity. They will use their knowledge to write information text to support an opinion.

### Curriculum Focus

Language Arts  
Social Studies  
Science

### Materials (per student group)

- Copies of "Student Sheet: Edison vs Holonyak"

### Key Vocabulary

LED (light-emitting diode)  
Incandescent bulb  
Filament  
Electric meter  
Inference  
Persuasive  
Lumen  
Watt

### Texas Essential Knowledge and Skills for Science

Grade 5  
(b) 3.C  
(b) 4.A  
(b) 8.A

Grade 6  
(b) 4.A



## Introduction

Thomas Edison and Nick Holonyak are two famous lighting inventors. They both made major contributions that changed the way people lived. Thomas Edison patented the incandescent bulb in 1880. Since that time, people have enjoyed the convenience of using electricity for light. Nick Holonyak created the first practical, visible spectrum LED which revamped lighting as we know it.

In this activity, students will study the contributions of these two inventors. They will gather details to form an opinion about which man was more influential in history.



## Procedure

1. Pass out copies of "Student Sheet: Edison vs Holonyak" and have students read about each. If time allows, they can use the internet, or other sources, to find additional information.
2. Have students fill out the research cards for each inventor. Using that information, they should decide which inventor was more influential in history and write a persuasive paragraph, with details from their research, to support their opinion.
3. Challenge students to practice reciting their paragraph and then present it to another student(s) in an attempt to change a differing opinion.



## Discussion

- What kinds of light bulbs are used in your home? How do they affect the way you live and work?
- What do you think the next great electrical invention will be?
- Thomas Edison said, "Genius is one percent inspiration and ninety-nine percent perspiration." What did he mean? How does his quote apply to you?



## To Know and Do More

A light bulb package has a lighting facts label that contains different numbers.

- The light output is shown in lumens.
- The power used by the bulbs is measured in Watts. The higher the wattage, the more energy the bulb uses.
- A measure of how warm or cool the light from that bulbs looks is measured in Kelvin (K). Low numbers are warmer light hues (orange or yellow). High numbers are cooler hues (blue or green).

When buying new bulbs, we should shop by lumens, not wattage. We save energy by finding bulbs with the lumens we need, then choosing the lowest wattage possible for that number of lumens.

<b>Lighting Facts</b>		per bulb
<b>Brightness</b>	<b>800 lumens</b>	
<b>Estimated Yearly Energy Cost \$1.08</b>		
Based on 3 hrs/day, 11¢/kWh Cost depends on rates and use		
<b>Life</b>	Based on 3 hrs/day	23 years
<b>Light Appearance</b>		
Warm	▲ 2700 K	Cool
<b>Energy Used</b>	<b>9 Watts</b>	

To learn more, visit [thinkenergy.org/XcelEnergy](https://thinkenergy.org/XcelEnergy).

## Student Sheet: Edison vs Holonyak



Early light bulbs could not be sold because they did not last long enough, were too expensive and used too much energy. In 1879 Thomas Edison improved the light bulb so that it lasted longer, 14.5 hours. He continued to test thousands of materials for the filament (the part of the bulb that produces light when heated by an electrical current) until his bulb could last 1,200 hours! Edison made other improvements to the early light bulb that made it good enough to be used in homes, schools and businesses.

Edison's work with electricity didn't stop at light bulbs. He improved the way electricity was generated and transported to places where it was needed. Edison also developed the first electric meter, a device which measures the amount of electricity used by a location or device. Edison was a hard worker who patented 1,093 of his inventions. His famous quote is, "Genius is one percent inspiration and ninety-nine percent perspiration." Thomas Edison's improvements to the way people used electricity and lighting changed the way they lived. Electricity helped get work done more quickly and easily. Electric light made it possible to do activities at night and to extend the time people could work or play.

What were two of Thomas Edison's accomplishments that made electric lighting possible?

What do you think was Thomas Edison's greatest strength as an inventor?



Nick Holonyak was an engineering professor from the University of Illinois who later went to work for General Electric. In 1962, when he was 33, he created the first practical, visible light-emitting diode (LED). Holonyak was trying to create a semiconductor laser, but instead he accidentally created something even more important, a light that would replace incandescent bulb. His coworkers called the red LED he created "the magic one."

Within the year, General Electric was selling LEDs. They started as indicator lights on electrical equipment. Then they were put in digital watches. By the end of the 1980s, LEDs were in traffic lights. Now LEDs are replacing less efficient light bulbs everywhere. Their price has gone down over 85 percent and continues to fall. LEDs help us save the natural resources that are used to generate electricity. This is because they use approximately 90 percent less energy and last up to 25 times longer than an incandescent bulb. By 2027, widespread use of LEDs could save more than \$30 billion at today's electricity prices.

What was interesting to you about Nick Holonyak's discovery of the red LED?

How did Nick Holonyak's discovery of the red LED help people today?

Compare the facts that you have learned about Edison and Holonyak. Which inventor do you think was more influential in history? Write a paragraph that states your opinion and gives two or more facts to support your opinion. Practice reciting the paragraph and read it to a classmate(s) with a different opinion. Did you change their mind?

## Layered Lunch

### Objective

Students will understand that natural gas deposits are trapped and held by certain types of geologic formations.

### Curriculum Focus

Science  
Art

### Materials\*

- Slices of bread
- Peanut butter or other thick spread (e.g. cream cheese)
- Honey
- Plastic wrap or wax paper
- Plastic knife

### Key Vocabulary

Permeable  
Impermeable  
Source rock

### Texas Essential Knowledge and Skills for Science

Grade 5  
(b) 1.B  
(b) 5.C  
(b) 6.A, B  
(b) 10.B  
(b) 11

Grade 6  
(b) 1.B  
(b) 5.C  
(b) 6.A  
(b) 11.A, B



## Introduction

How do we find natural gas? Try this activity to get an idea of the type of rock formations and characteristics geologists look for when locating natural gas deposits.

As natural gas molecules form, they migrate from shale source rock into more porous areas such as sandstone. Porous or permeable layers are much like a sponge with little pockets throughout the rock. The natural gas continues to move to either the earth's surface (where it escapes into the atmosphere) or it is trapped when nonporous or impermeable rock layers block its path.



## Procedure

Using bread, peanut butter and honey, create some edible models of rock layers. \*Please ensure no one in your classroom has an allergy to any food items you may use.

1. Spread thick layers of peanut butter then honey on a slice of bread. Top it with another slice of bread.
2. Make a second sandwich just like the first or gently cut the sandwich in half.
3. Now put one sandwich (or one half) with the peanut butter layer above the honey and the other sandwich (or other half) with the honey on top of the peanut butter on top of one another.
4. Next, spread a thick layer of only honey on a slice of bread, adding another slice on top.
5. Cover your sandwiches with wax paper or plastic wrap and gently press down on them for about three seconds, representing millions of years of pressure.
6. Cut the sandwiches in half and observe what has happened.



## Discussion

1. What do you think the honey represents?
2. Which layer do you think represents porous rock?
3. Which layer is the nonporous rock?
4. Did the honey seep into both slices of bread? Why or why not?
5. What do you predict would happen with a sandwich made with only peanut butter?
6. How might the ingredients you used affect your results?
7. Draw the layers of your sandwich and use colored pencils or crayons to distinguish the different layers and write labels for each layer that include: impermeable, permeable, natural gas, nonporous rock and porous rock.

## Answers

The honey represented natural gas or a fossil fuel. The bread was the porous rock where the honey or natural gas gets into the little pockets or air spaces. Peanut butter acted like a nonporous rock layer blocking the honey from seeping into the slice of bread above the peanut butter. The results may be different depending on your ingredients: denser bread allows less seepage, creamier peanut butter may be less impermeable or thicker honey may not fill the little pockets as easily.



## To Know and Do More

Assign students to further investigate how natural gas is trapped in rock formations. Have them draw pictures of a formation and the trapping of oil and natural gas in the earth.

Visit a natural history museum and look for prehistoric life forms and rock formations.

## Natural Gas Mix and Match

### Objective

Students will learn about natural gas as a source of energy by matching subject phrases with predicate phrases.

### Curriculum Focus

Science  
Language Arts  
Art

### Materials

- Copies of "Subject Cards" printed on white paper for half the class
- Copies of "Predicate Cards" printed on colored paper for half the class

### Key Vocabulary

Fossil fuel  
Methane  
Natural gas

### Texas Essential Knowledge and Skills for Science

Grade 5  
(b) 10.B  
(b) 11

Grade 6  
(b) 11.A, B



## Introduction

Natural gas is a nonrenewable fossil fuel that is used to power appliances or transportation in a reliable and efficient manner. Furnaces, water heaters, fireplaces and clothes dryers are just a few of the appliances that use natural gas. Natural gas can be compressed under high pressure and in that form is used as transportation fuel in cars, commercial trucks and buses.



## Procedure

1. Ask the students the following questions to assess their knowledge of the subject and to stimulate interest in the activity:
  - Do you use natural gas in your homes?
  - Do you think cars can run using natural gas?
2. Discuss with the students natural gas and the many ways it is used. Explain why the color of a natural gas flame is blue. (complete combustion)
3. Pass the cards to the students and have them cut them apart.
4. Instruct the students to move about the room, comparing cards with each other, until they find a card of a different color that matches with theirs to complete a sentence. Students will then read their matches and identify the subject and predicate phrase.
  - Examples of correctly paired cards:
    - Subject - Predicate
    - A furnace - keeps our homes warm.
    - Blue - is the color of a natural gas flame.
    - Electricity - can be generated using natural gas.
    - Natural gas - is a fossil fuel, mostly methane.
5. Have students write a new predicate phrase for one of the subject phrases.
6. Have the students write a complete sentence using their subject or predicate phrase.





---

## Discussion

Instruct students to make a list of ways natural gas is used in their homes. Compare lists in class and discuss the various uses. Have students draw and color a picture of an important natural gas appliance in their home.



---

## To Know and Do More

Have students brainstorm safety tips regarding natural gas appliances. Some safety tips are:

- Never hit natural gas appliances or equipment (like outside meters) with anything like a stick, rock, bat or ball.
- Do not climb or jump on natural gas appliances or equipment.
- Keep the area around natural gas appliances or equipment clear and clutter free.
- Do not store paint cans, aerosol cans or other flammable materials around natural gas appliances.

## Subject Cards

A meter	A water heater
A natural gas range	A furnace
Some cars	Blue
A natural gas grill	Natural gas
Farmers	New uses of natural gas
Electricity	A natural gas dryer
A natural gas fireplace	

## Predicate Cards

is an instrument that measures the amount of natural gas used.	is needed for a hot bath or shower.
is used to bake cookies.	keeps our home warm.
is the color of a natural gas flame.	is great for year-round outdoor cooking.
are developed every day.	use fertilizer made from natural gas on their crops.
can be generated using natural gas.	makes laundry chores fast and convenient.
provides warmth on a snowy night.	is a fossil fuel, mostly methane.
use natural gas as a fuel.	

# Water Inside and Out

<p><b>Objective</b></p> <p>Students will understand the finite nature of water in the water cycle and learn ways to use water efficiently at home.</p> <p><b>Curriculum Focus</b></p> <p>Language Arts Science Social Studies</p>	<p><b>Materials (per team or for demonstration)</b></p> <ul style="list-style-type: none"> <li>Copies of "Student Sheet: The Green Patrol" and "Student Sheet: Get a Load of This"</li> </ul>	<p><b>Key Vocabulary</b></p> <p>Efficiency Evaporation Condensation Precipitation Hydrologic cycle</p>	<p><b>Texas Essential Knowledge and Skills for Science</b></p> <p>Grade 5 (b) 1.B (b) 5.C, D (b) 6.A (b) 10.A, B (b) 11 (b) 12.C</p> <p>Grade 6 (b) 1.B (b) 5.C, D (b) 6.A (b) 11.A, B</p>
---	---	--	--



## Introduction

Water moves continuously between the sky and earth. Moisture falls, evaporates, rises, then condenses and falls again in the form of precipitation. The water cycle, or hydrologic cycle, is a marvelous phenomenon of nature. You are drinking, bathing, swimming and making snowballs from the same water on which Columbus sailed to America and the same water dinosaurs drank.

Water is one of our most valuable resources. We need it to stay alive, to produce our food, to keep us clean and to do many other things. We want to be wise stewards of such a vital resource by keeping our water supply clean and using it wisely. There are many easy things we can do to use water more efficiently at home.

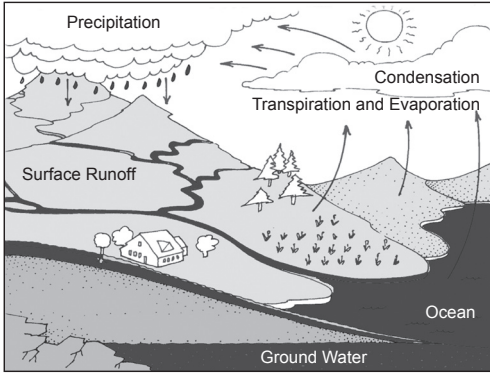

## Procedure

1. Discuss with students the ways they keep their yards beautiful. Do they prune their bushes and trees? Do they plant flowers? All of these things are important, but if they do not water the plants, all of the landscaping in their yards will die.
2. Pass out "Student Sheet: The Green Patrol." Have each student take the activity home and complete it with their family. Discuss their findings in class.
3. Water can also be wasted in the kitchen and laundry room. Pass out "Student Sheet: Get a Load of This." Have students complete the activity and then discuss their findings in class.



## Discussion

List the changes or adjustments that the students have made concerning their water use.



## To Know and Do More

Have students create their own mini water cycle in a quart sized bag.

Draw and label the major processes of the water cycle: precipitation, condensation, evaporation and transpiration. Pour 2 ounces of water into the bag. Mark the water line using a permanent marker. Tightly seal the bag and tape it to a wall or window in a sunny, hot area.

Observe the water level for 3 to 5 days and record how energy transforms water in the water cycle. Ask students to hypothesize what will happen to the water level in the bag over time.

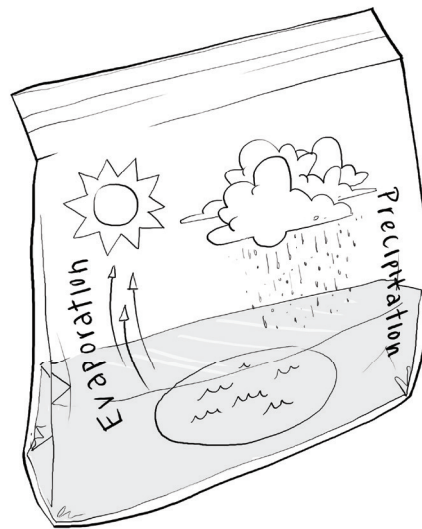

## Student Sheet: The Green Patrol

In the summer, how is most household water used? Do you think it is for:

- a. Washing clothes
- b. Watering the lawn
- c. Washing the dishes

If you guessed "b" you are right! During the summer, most household water is used to keep the grass green and our plants growing. The trouble is we often use more water than necessary! This is a problem when we do not have enough water. Wasting water also wastes energy because it takes energy to clean, transport and heat water.

### Water-saving Tips in the Yard

- Water your lawn early in the morning or late in the evening to avoid loss of water due to evaporation.
- Have an adult set the mower blades at a 2 to 3 inch height. The ground beneath taller grass does not dry out as fast as the ground beneath shorter grass.
- Plant native trees and shrubs that do not require a lot of water and need a minimal amount of care.
- Spread fine mulch over your flower beds to help keep the ground moist.

Here is an interesting way to determine the length of time you need to water your lawn:

You will need:

- A hose
- Three short cans (tuna or pet food)
- A ruler
- A sprinkler
- A watch or timer

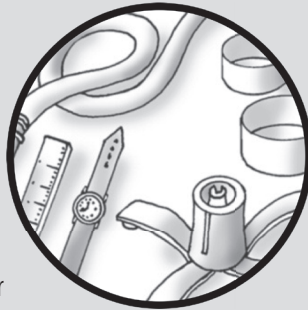

1. Set the hose and sprinkler in the yard, then set the cans around the sprinkler. Set one close to it, one far away and the third at a medium distance.

2. Turn the sprinkler on and note the time. Every few minutes, use the ruler to measure how much water is in each can. When a can fills with an inch of water, note the time. Write down how long it takes for each can to fill with an inch of water.
3. Add the measured times together and divide by three to get an average. That average time is how long you need to water your lawn each week.
4. Discuss your findings with your family. What do your results mean for your home?



## Student Sheet: Get a Load of This

**Take the quiz to see how your family could save loads of water and energy!**

Do you wash full loads of dishes or clothes? Y N

Do you use shorter cycles with the dishwasher, clothes washer and dryer? Y N

Do you use the air-dry setting on your dishwasher or hang laundry to dry? Y N

When hand washing dishes, do you not let the water run? Y N

When shopping for fixtures and appliances that use water, do you look for those that are efficient? Y N

Do you wash clothes in cold water when possible to save the energy that heats water? Y N

Do you clean the lint filter on your clothes dryer after each load? Y N

Total Points \_\_\_\_\_

(Score 5 points for each Yes)

How did you score?

30 and above: Washing dynamo!

25 to 30: You have room to save.

20 and below: Keep trying!

Did you know that water leaks in your home can waste enough water to fill a backyard swimming pool in just one year? Fixing these leaks can save your family more than 10 percent on water bills. Let's go on a leak hunt!

- Walk through your home listening for drips. They usually mean leaks.
- If you think you hear a leak, ask an adult to help you find the water meter. The numbers in the box represent gallons or cubic feet of water used in your home. Look at this number before a time when you will not be using any water. At least two hours later, check the number again. If it has changed, you probably have a leak somewhere in your home.



## The Cost of Looking Your Best

### Objective

Students will investigate the amount of energy used at home in a day, determine how much is wasted and discover ways they can save and use energy more efficiently.

### Curriculum Focus

Math  
Science  
Social Studies

### Materials

- "Student Sheet: The Cost of Looking Your Best"

### Key Vocabulary

Energy efficiency  
Environmentally responsible  
Responsible  
Stewards

### Texas Essential Knowledge and Skills for Science

Grade 5  
(b) 5.C  
(b) 11  
(b) 12.C

Grade 6  
(b) 5.C  
(b) 11.A, B



### Introduction

Without even thinking about it we use energy every day to clean our clothes, cook our food and look our best. We do not consider where this energy comes from while blow-drying our hair; it is just always there. However, we do not have an endless supply. Our energy, natural resources, environment and lifestyle are tightly interconnected.

Every time we use energy we use natural resources and we affect our environment. As we become more aware of this, it helps us make better choices, reduce our energy waste and be good stewards of our resources. As we learn to be more environmentally responsible, we can influence others to be wise energy users, too.



### Procedure

1. Discuss with students how much energy they use in the morning to get ready for school. Make a list on the board of items they use that require energy. Do not forget the alarm clock, toothbrush, lights, air conditioner, furnace and so on.
2. Pass out "Student Sheet: The Cost of Looking Your Best" Have students take the activity home and complete it with their families. Allow time in a few days to discuss their findings. What factors made the differences in each student's use? Have students come up with simple tips to conserve while still looking their best.



### Discussion

Discuss energy use in students' great-great-grandparents' day. What energy did it take for them to look their best? Did it take them longer to get ready?





## To Know and Do More

Using a beach ball, label alternating sections with "Expert Energy Saver" and "Energy Saving Skills." Divide students into two teams; toss the ball back and forth, giving each student an opportunity to catch it. When a student catches the ball, if their left thumb lands on "Expert Energy Saver," their team gets a point; if it lands on "Energy Saving Skills," they can earn two points for giving an energy saving tip.

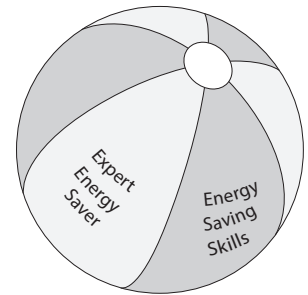

## Career Awareness Activity

Brainstorm with the students to think of all the careers that help us look our best: hair stylists, dry cleaners, dentists, plastic surgeons, etc. Discuss the energy usage and energy needs of these different careers.

## Student Sheet: The Cost of Looking Your Best

It takes energy to look your best. Energy is needed to shower, blow-dry your hair, brush your teeth and wash and dry your clothes. Use the chart below to estimate the energy costs for looking your best.

### Here Is How:

- In the column labeled "Times/Year," record how often you perform that activity in a year.
- In each row, multiply the number in the "Units" column by the amount in the "Cost/Activity" column and then by the number you recorded in the "Times/Year" column to determine a subtotal cost for that activity.
- Add together each subtotal for your total annual energy cost for these activities.
- Multiply this number by the number of family members in your home for a grand total.

Activity	Units	Cost/Activity	Times/Year	Annual Subtotals
Shower	17 gallons	x \$0.01/gallon	x _____	\$ _____
Bath	36 gallons	x \$0.01/gallon	x _____	\$ _____
Hand/Face Wash	1 gallon	x \$0.01/gallon	x _____ (Estimate washes/day x 365)	\$ _____
Hair Dryer 5 minutes (1500 W)	0.125 kWh	x \$0.1372/kWh	x _____	\$ _____
Washing Clothes in Hot Water	20 gallons	x \$0.01/gallon	x _____ (Estimate loads/week x 52 weeks)	\$ _____
Drying Clothes	1 load	x \$0.41/load	x _____ (Estimate loads/week x 52 weeks)	\$ _____

**Total Annual Cost for You** \$ \_\_\_\_\_

(x \_\_\_\_ **Number of Family Members**) = **Total Annual Energy Cost for Your Family** \$ \_\_\_\_\_

Hair dryer and clothes dryer costs based on the use of electricity at a rate of \$0.1372/kWh.

A photograph of a diverse group of students in a classroom. In the foreground, a young girl with curly hair is smiling and holding a tablet. Behind her, other students are seated at desks, some using laptops. The scene is brightly lit and shows a positive learning environment.

# REWARDING RESULTS

## Reward Your Students

Give students a scented highlighter when they complete their *Home Energy Worksheet* (HEW) on paper or online at [thinkenergy.org/XcelEnergy](http://thinkenergy.org/XcelEnergy).

Giving a completion grade or extra credit may encourage students to complete the HEW.

## Reward Yourself

Earn a second gift card when your class submits the HEW on paper or online.

- \$25 for 80% or more
- \$15 for 50% to 79%
- \$10 for less than 50%

Offer only available to teachers with students participating in the Xcel Energy School Education program. Certain restrictions may apply.

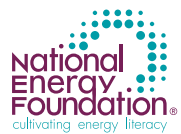

Questions? Call or go online today.

800-616-8326 ext. 170 [thinkenergy.org/XcelEnergy](http://thinkenergy.org/XcelEnergy)

